

SAIBO



TELESCOPIC RAILS

TELESCOPIC RAILS

SAIBO Telescopic Rails are designed for heavy duty industrial applications which require smooth telescopic sliding with no play. These applications include such as Automated Warehousing systems, Electric Vehicle's Battery Boxes.

The structure of these rails is very simple and compact. There is one C-shaped external rail, one internal slider, two rows of steel balls and a ball cage total. Limit Stoppers are fixed both in external rail and internal slider to preset the extension ranges. From cross section, there are V-shaped concaves in external rail and internal slider, balls run in the concaves with 4 points contact. Zero clearance is set between balls and concaves during assembling and this is most important for precise sliding. This 4-points contact structure achieve very small displacement forces and acceleration forces. It also could get a very good stiffness.

Both external rail and internal slider are made of cold draw steel with induction hardening in the ball races. Thus, these products achieve a high wear resistance, heavy load capacity and good durability.

The simplest type of these series products is one internal slider runs in an external rail. We call this Partial Extension. This is the base component and could be built to another Full Extension slides flexibly.

At present, there are two sizes are available, size28 and size43.

TPE
Partial Extension Rails

The internal slider could extract for more than half of its length from the edge of the external rail. Using shorter ball cage could get longer extract length. But this will reduce load capacity.



TDB
Full Extension Rails

This series products permit full extension. It is assembled with two Partial Extension Rails which are bolted back to back. This rail's stroke could reach slider's full length and even more.



TLB
Ball-Caged Linear Guides

This series products' ball cage and internal slider are limited in the external C-shaped rail. Then the internal slider can not extract out external C-shaped rail.



Double Directions

If need double directions extraction, just remove the stop screw, Then the internal slider could extract in both directions.

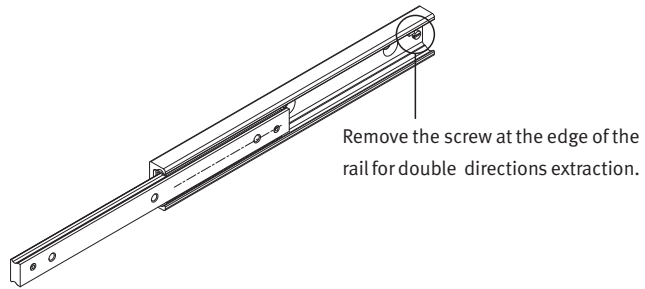

Working Speed

The maximum working speed is 0.8m/s. But this maximum speed could reduce influenced by the length of ball cage and internal slider, installation and application. If application condition is good and installation is perfect, the most influence factor is rail's length. Please refer the maximum speed as below chart.

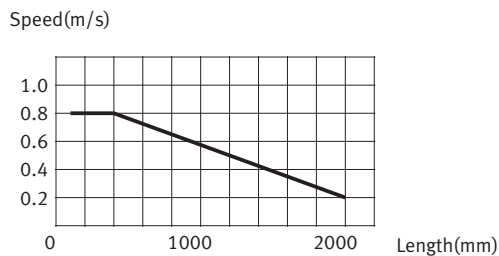

Lubrication and Temperature

High quality lubrication is helpful for rail's working life. It also could reduce running noise. In delivery status, all products are filled lubricate in the ball races which allows to work in the temperature between -20 °C and 120 °C . It is commended to re-lubricate each 100Km running.

The rail steel bodies' maximum working temperature is 170 °C . In higher temperature working conditions, the ball races' hardness will be reduced undergo the tempering process. Then the load capacity would reduce. For extreme working temperature, please contact our technical service.

Load Capacity

These Cold-drawn Steel Rails are designed for heavy load capacity. The load capacity is most different to those steel sheet bended drawer rails. Please check detailed parameters in each product's load capacity table.

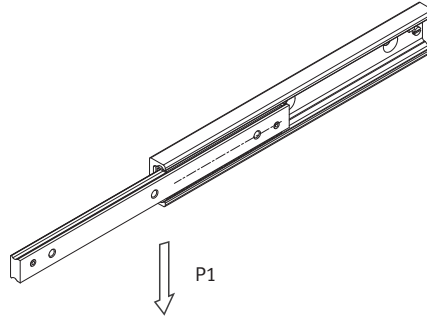

All the maximum permissible load showing in the table is tested in the center of extracted slider in the status of completely extraction.

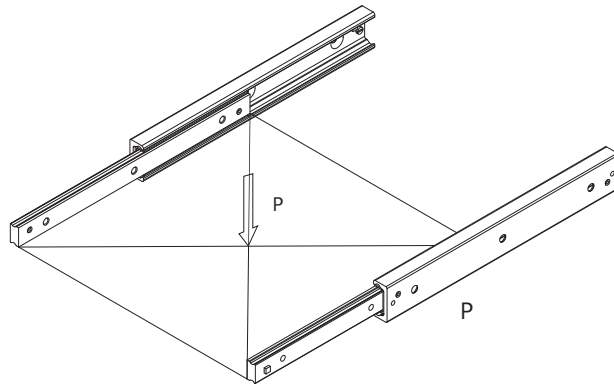

When two telescopic rails are mounted parallelly in ideal and the load is distributed on each rail uniformly. This drawer's maximum load P is double of one single rail's load capacity.

$$P=2 P1$$

Life Calculation

Telescopic Rail's life is determined by several factors. These factors include effective load, running direction change frequency, running speed, installation precision, vibration or shock, working condition and temperature, lubricate etc.

Equivalent Load LF

$$LF = F_y + \left(\frac{F_z}{Coax} + \frac{M_x}{M_{xmax}} + \frac{M_y}{M_{ymax}} + \frac{M_z}{M_{zmax}} \right) Corad$$

F_y – Actual load in Y direction (N)

F_z – Actual load in Z direction (N)

M_x - Actual moment load in X directiron (N.m)

M_y - Actual moment load in Y directiron (N.m)

M_z - Actual moment load in Z directiron (N.m)

(Below Parameters can be taken from the table of Load Capacity)

$Corad$ – Load capacity in Y direction (N)

$Coax$ –Load capacity in Z direction (N)

M_{xmax} -Moment capacity in X directiron (N.m)

M_{ymax} -Moment capacity in Y directiron (N.m)

M_{zmax} -Moment capacity in Z directiron (N.m)

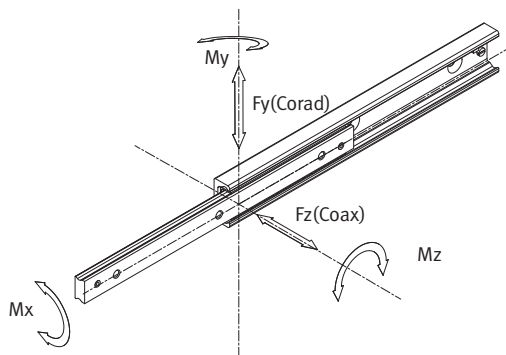

Life in Kilometers

$$L_{km} = 100 \cdot \left(\frac{C_{100}}{LF \cdot f} \right)^3$$

C100 – Load capacity factor.

(Please check detailed parameter each product's load capacity table)

f – Application Coefficient

None vibration or shock, Low speed Low frequency shift direction, clean environment.	1.3-1.8
Light vibration or shock, medium speed medium frequency shift direction, some dirtiness	1.8-2.3
Heavy vibration or shock, high speed high frequency shift direction, heavy dirty	2.3-3.5

TPE Cross-Section Dimension

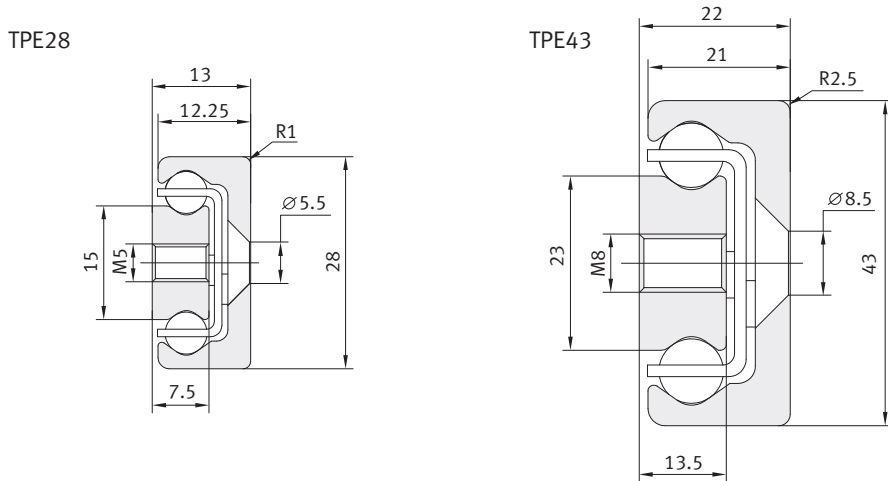

Load Capacity

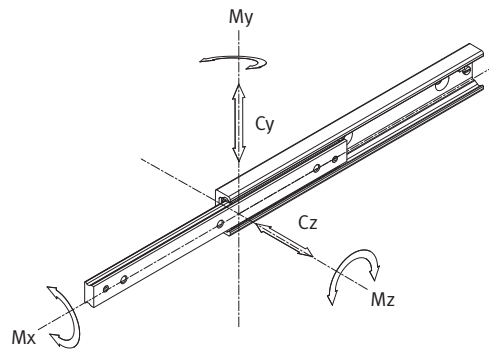

Type	Length L (mm)	Stroke S (mm)	Load Capacity					C_{100} (N)
			C_y (N)	C_z (N)	M_x (Nm)	M_y (Nm)	M_z (Nm)	
TPE28-130	130	74	612	430	16	21	29	873
TPE28-210	210	116	1117	782	27	59	83	1579
TPE28-290	290	148	1935	1355	40	133	187	2693
TPE28-370	370	190	2446	1712	51	214	306	3403
TPE28-450	450	232	2956	2070	62	315	450	4120
TPE28-530	530	274	3467	2427	73	436	620	4835
TPE28-610	610	316	3978	2785	83	577	820	5558
TPE28-690	690	358	4489	3142	94	736	1051	6273
TPE28-770	770	400	4996	3499	105	915	1308	6985
TPE28-850	850	433	5829	4082	118	1166	1667	8113
TPE28-930	930	475	6336	4437	130	1390	1985	8810
TPE28-1010	1010	517	6849	4795	140	1633	2329	9526
TPE28-1090	1090	559	7359	5150	151	1894	2704	10239
TPE28-1170	1170	601	7566	5508	162	2176	3109	10953

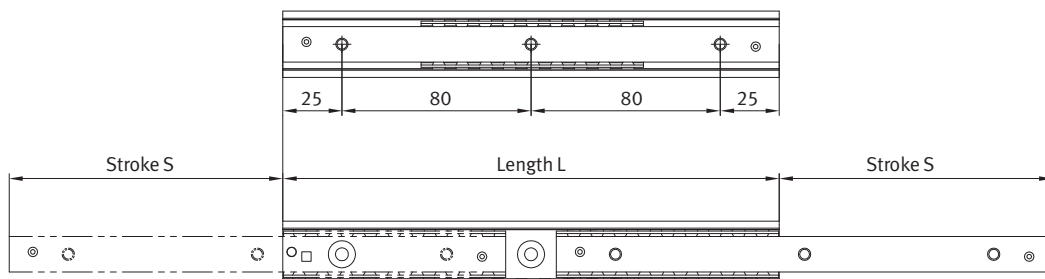

Type	Length L (mm)	Stroke S (mm)	Load Capacity					C_{100} (N)
			C_y (N)	C_z (N)	M_x (Nm)	M_y (Nm)	M_z (Nm)	
TPE43-210	210	123	1596	1118	61	85	121	2288
TPE43-290	290	158	2873	2012	94	202	289	4055
TPE43-370	370	208	3378	2365	116	307	441	4794
TPE43-450	450	243	4691	3285	150	510	730	6602
TPE43-530	530	278	6040	4228	185	763	1089	8451
TPE43-610	610	313	7412	5189	216	1065	1520	10325
TPE43-690	690	363	7865	5506	238	1295	1850	11007
TPE43-770	770	398	9233	6465	273	1682	2403	12879
TPE43-850	850	433	10617	7132	305	2120	3029	14763
TPE43-930	930	483	11056	7740	328	2440	3485	15430
TPE43-1010	1010	518	12435	8705	360	2962	4231	17311
TPE43-1090	1090	568	12878	9015	383	3336	4767	1981
TPE43-1170	1170	603	14256	9980	416	3945	5635	19861
TPE43-1250	1250	638	15640	10948	450	4597	6572	21749
TPE43-1330	1330	688	16076	11255	471	5066	7238	22412
TPE43-1410	1410	723	17458	12220	504	5806	8296	24298
TPE43-1490	1490	758	18848	13192	538	6599	9426	26187
TPE43-1570	1570	793	20240	14168	571	7442	10630	28085
TPE43-1650	1650	843	20663	14465	593	8031	11473	28735
TPE43-1730	1730	878	22055	15438	626	8958	12796	30628
TPE43-1810	1810	928	22480	15738	648	9604	13718	31280
TPE43-1890	1890	963	23865	16709	682	10615	15163	33170
TPE43-1970	1970	1013	24230	17010	705	11315	16162	33827

TDB Cross-Section Dimension

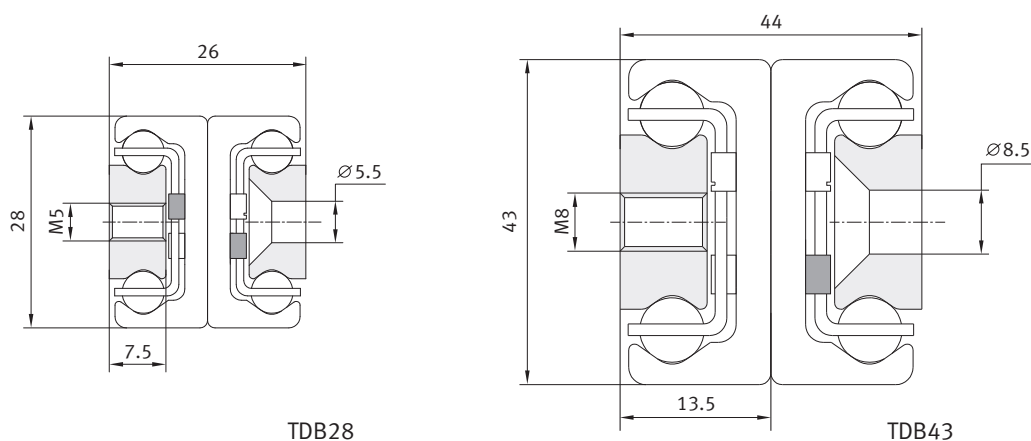

Load Capacity

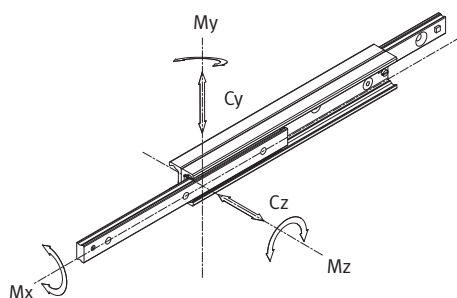

Type	Length L (mm)	Stroke S (mm)	Load Capacity		C_{100} (N)
			C_y (N)	C_z (N)	
TDB28-130	130	148	236	165	358
TDB28-210	210	232	433	303	656
TDB28-290	290	296	768	538	1155
TDB28-370	370	380	969	472	1157
TDB28-450	450	464	1170	386	1760
TDB28-530	530	548	1108	326	2065
TDB28-610	610	633	956	281	2370
TDB28-690	690	717	845	248	2673
TDB28-770	770	801	754	220	2978
TDB28-850	850	866	712	209	3489
TDB28-930	930	950	647	190	3785
TDB28-1010	1010	1034	593	175	1088
TDB28-1090	1090	1118	548	161	4389
TDB28-1170	1170	1202	509	150	4691

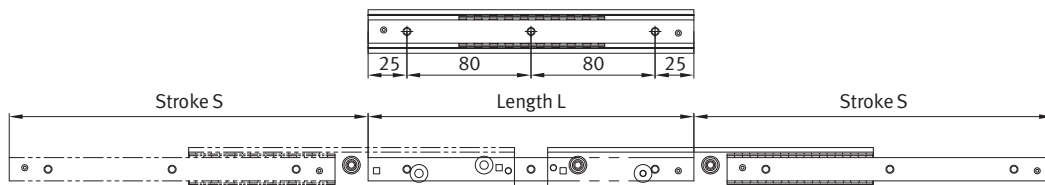

Type	Length L (mm)	Stroke S (mm)	Load Capacity		C_{100} (N)
			C_y (N)	C_z (N)	
TDB43-210	210	246	606	425	923
TDB43-290	290	316	1115	781	1687
TDB43-370	370	416	1302	912	1974
TDB43-450	450	486	1827	1280	2764
TDB43-530	530	556	2376	1435	3580
TDB43-610	610	626	2935	1303	4414
TDB43-690	690	726	3092	1096	4661
TDB43-770	770	796	3056	1018	5493
TDB43-850	850	866	2848	945	6335
TDB43-930	930	966	2508	835	6572
TDB43-1010	1010	1036	2365	788	7411
TDB43-1090	1090	1106	2239	745	8257
TDB43-1170	1170	1206	2020	673	8489
TDB43-1250	1250	1276	1929	642	9332
TDB43-1330	1330	1376	1767	588	9568
TDB43-1410	1410	1446	1965	565	10409
TDB43-1490	1490	1516	1628	542	11255
TDB43-1570	1570	1586	1568	523	12105
TDB43-1650	1650	1686	1460	487	12330
TDB43-1730	1730	1756	1407	470	13178
TDB43-1810	1810	1856	1322	440	13406
TDB43-1890	1890	1926	1281	426	14252
TDB43-1970	1970	2026	1207	402	14483

TLB Cross-Section Dimension

TLB28

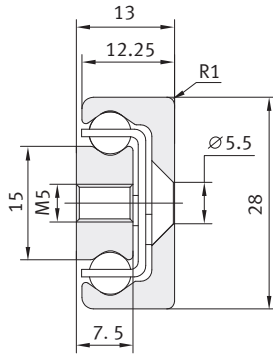

TLB43

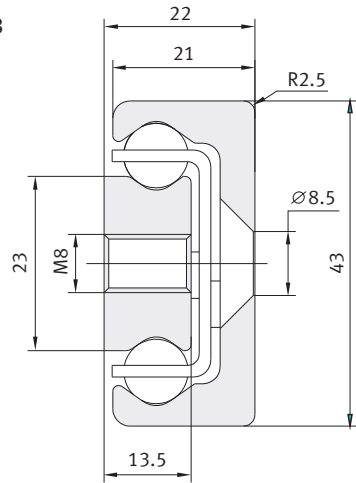

Load Capacity

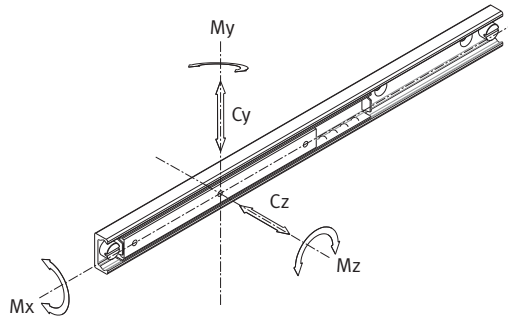

Type	Carriage										
	Dimension				Load Capacity					C_{100} (N)	No. of holes
	D (mm)	A (mm)	B (mm)	C (mm)	C_y (N)	C_z (N)	M_x (Nm)	M_y (Nm)	M_z (Nm)		
TLB28-60	20	60	10	20	3481	2438	17	25	36	3481	3
TLB28-80	20	80	10	20	4642	3249	23	44	63	4642	4
TLB28-130	20	130	25	80	7542	5279	37	115	162	7542	2
TLB28-210	20	210	25	80	12182	8525	60	299	427	12182	3
TLB28-290	20	290	25	80	16823	11775	83	570	812	16823	4
TLB28-370	20	370	25	80	21461	15024	106	927	1324	21461	5
TLB28-450	20	450	25	80	26103	18272	128	1372	1959	26103	6

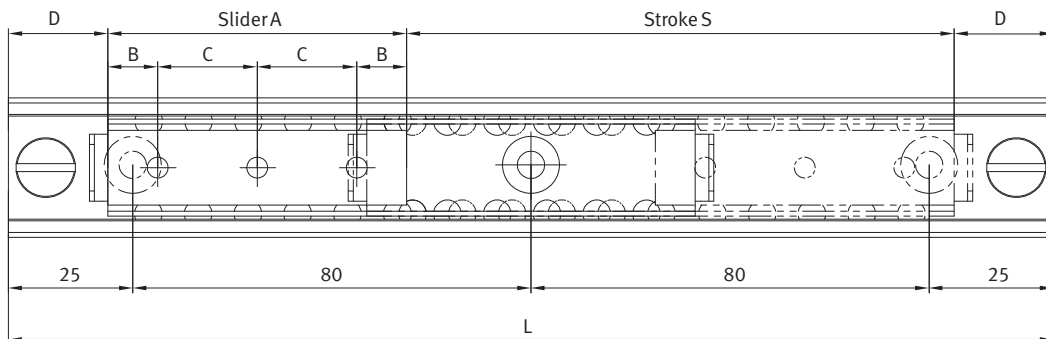

Type	Carriage										
	Dimension				Load Capacity					C ₁₀₀ (N)	No. of holes
	D (mm)	A (mm)	B (mm)	C (mm)	C _y (N)	C _z (N)	M _x (Nm)	M _y (Nm)	M _z (Nm)		
TLB43-130	25	130	25	80	13912	9738	97	212	302	13912	2
TLB43-210	25	210	25	80	22471	15730	156	550	786	22471	3
TLB43-290	25	290	25	80	31032	21723	215	1051	1503	31032	4
TLB43-370	25	370	25	80	39592	27715	272	1710	2442	39592	5
TLB43-450	25	450	25	80	48151	33704	333	2528	3612	48151	6
TLB43-530	25	530	25	80	56713	39698	392	3508	5010	56713	7
TLB43-610	25	610	25	80	65272	45689	451	4646	6637	65272	8

TLB Standard Length

Type	Rail Length	Carriage Lebgh	Stroke
TLB28-130-60-30	130	60	30
TLB28-210-60-110	210	60	110
TLB28-290-60-190	290	60	190
TLB28-370-60-270	370	60	270
TLB28-450-60-350	450	60	350
TLB28-210-80-90	210	80	90
TLB28-290-80-170	290	80	170
TLB28-370-80-250	370	80	250
TLB28-450-80-330	450	80	330
TLB28-530-80-410	530	80	410
TLB28-610-80-490	610	80	490
TLB28-290-130-120	290	130	120
TLB28-370-130-200	370	130	200
TLB28-450-130-280	450	130	280
TLB28-530-130-360	530	130	360
TLB28-610-130-440	610	130	440
TLB28-690-130-520	690	130	520
TLB28-770-130-600	770	130	600
TLB28-850-130-680	850	130	680
TLB28-930-130-760	930	130	760
TLB28-1010-130-840	1010	130	840
TLB28-450-210-200	450	210	200
TLB28-530-210-280	530	210	280
TLB28-610-210-360	610	210	360
TLB28-690-210-440	690	210	440
TLB28-770-210-520	770	210	520
TLB28-850-210-600	850	210	600
TLB28-930-210-680	930	210	680
TLB28-1010-210-760	1010	210	760
TLB28-1170-210-920	1170	210	920
TLB28-1330-210-1080	1330	210	1080
TLB28-610-290-280	610	290	280
TLB28-690-290-360	690	290	360
TLB28-770-290-440	770	290	440
TLB28-850-290-520	850	290	520
TLB28-930-290-600	930	290	600
TLB28-1010-290-680	1010	290	680
TLB28-1170-290-840	1170	290	840
TLB28-1330-290-1000	1330	290	1000
TLB28-1490-290-1160	1490	290	1160
TLB28-770-370-360	770	370	360
TLB28-850-370-440	850	370	440
TLB28-930-370-520	930	370	520
TLB28-1010-370-600	1010	370	600
TLB28-1170-370-760	1170	370	760
TLB28-1330-370-920	1330	370	920
TLB28-1490-370-1080	1490	370	1080
TLB28-930-450-440	930	450	440
TLB28-1010-450-520	1010	450	520
TLB28-1170-450-680	1170	450	680
TLB28-1330-450-840	1330	450	840
TLB28-1490-450-1000	1490	450	1000
TLB28-1650-450-1160	1650	450	1160

TLB Standard Length

Type	Rail Length	Carriage Length	Stroke
TLB43-290-130-110	290	130	110
TLB43-370-130-190	370	130	190
TLB43-450-130-270	450	130	270
TLB43-530-130-350	530	130	350
TLB43-610-130-430	610	130	430
TLB43-690-130-510	690	130	510
TLB43-770-130-590	770	130	590
TLB43-850-130-670	850	130	670
TLB43-930-130-750	930	130	750
TLB43-1010-130-830	1010	130	830
TLB43-450-210-190	450	210	190
TLB43-530-210-270	530	210	270
TLB43-610-210-350	610	210	350
TLB43-690-210-430	690	210	430
TLB43-770-210-510	770	210	510
TLB43-850-210-590	850	210	590
TLB43-930-210-670	930	210	670
TLB43-1010-210-750	1010	210	750
TLB43-1170-210-910	1170	210	910
TLB43-1330-210-1070	1330	210	1070
TLB43-1490-210-1230	1490	210	1230
TLB43-1650-210-1390	1650	210	1390
TLB43-610-290-270	610	290	270
TLB43-690-290-350	690	290	350
TLB43-770-290-430	770	290	430
TLB43-850-290-510	850	290	510
TLB43-930-290-590	930	290	590
TLB43-1010-290-670	1010	290	670
TLB43-1170-290-830	1170	290	830
TLB43-1330-290-990	1330	290	990
TLB43-1490-290-1150	1490	290	1150
TLB43-1650-290-1310	1650	290	1310
TLB43-1810-290-1470	1810	290	1470
TLB43-770-370-350	770	370	350
TLB43-850-370-430	850	370	430
TLB43-930-370-510	930	370	510
TLB43-1010-370-590	1010	370	590
TLB43-1170-370-750	1170	370	750
TLB43-1330-370-910	1330	370	910
TLB43-1490-370-1070	1490	370	1070
TLB43-1650-370-1230	1650	370	1230
TLB43-1810-370-1390	1810	370	1390
TLB43-930-450-430	930	450	430
TLB43-1010-450-510	1010	450	510
TLB43-1170-450-670	1170	450	670
TLB43-1330-450-830	1330	450	830
TLB43-1490-450-990	1490	450	990
TLB43-1650-450-1150	1650	450	1150
TLB43-1810-450-1310	1810	450	1310
TLB43-1970-450-1470	1970	450	1470
TLB43-1170-530-590	1170	530	590
TLB43-1330-530-750	1330	530	750
TLB43-1490-530-910	1490	530	910
TLB43-1650-530-1070	1650	530	1070
TLB43-1810-530-1230	1810	530	1230
TLB43-1970-530-1390	1970	530	1390
TLB43-1330-610-670	1330	610	670
TLB43-1490-610-830	1490	610	830
TLB43-1650-610-990	1650	610	990
TLB43-1810-610-1150	1810	610	1150
TLB43-1970-610-1310	1970	610	1310

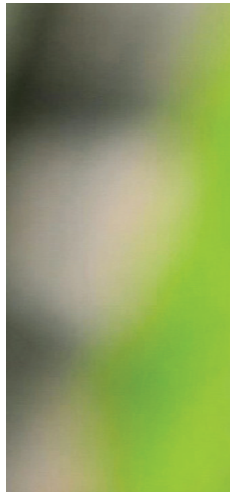

WUXI SAIBO INDUSTRY CO LIMITED
6-701 XIHU EAST ROAD, WUXI 214011, CHINA
Tel: +86-510-8203 9930
Fax: +86-510-8230 0096

www.saibo-bearing.com
info@saibo-bearing.com



SB2018 No.5 EN